

Constrained Optimal Control

The Algebraic Approach

VLADIMÍR KUČERA

In a recent series of papers the author has developed a new algebraic theory of discrete optimal control. The theory is based on polynomial algebra and the synthesis procedure is reduced to solving a linear Diophantine equation in polynomials. This is both conceptually simpler and computationally superior to existing methods. In this paper full advantage of the approach is taken to pose and solve discrete optimal control problems with various constraints.

INTRODUCTION

There are two basic criteria of optimality for discrete linear control systems, viz. optimality in the minimum time and the least squares sense. Their significance stems from the fact that they yield a linear control law and, therefore, make the problem well treatable. Succinctly speaking the minimum time criterion calls for zeroing the error in a minimum time and thereafter, while the least squares criterion minimizes the quadratic norm of the error. An advantage of the minimum time criterion is that the error vanishes after a finite number of time units. On the other hand, its serious drawback is that the optimal strategy may require large controls. They may saturate the system or produce large transient errors.

It is more realistic, therefore, to require that the largest control or the largest error should not exceed a given bound, in addition to the minimum time requirement. Alternatively, we can bound the error indirectly by allowing a longer settling time and minimizing the quadratic norm of the error. The basic observation is that all these constrained optimal control problems yield again a linear control law.

If we tried to bound the control sequence in the least squares control problem, we would obtain a non-linear control law. Such problems do not fall within the scope of this paper.

The theory given in the paper is valid for any finite dimensional, discrete, linear, single-input, single-output system defined over an arbitrary subfield of the field of complex numbers.

The basic mathematical tool of the paper will be the polynomial algebra. For basic definitions of a ring, units of a ring, divisibility in a ring, the fundamental concept of a field and other concepts used throughout the paper the reader is referred to [2], [5].

Given a field \mathbf{F} , which is a subfield of the field of complex numbers, we consider the ring $\mathbf{F}[z^{-1}]$ of polynomials over \mathbf{F} in the indeterminate z^{-1} . Let

$$a = \alpha_0 + \alpha_1 z^{-1} + \dots + \alpha_n z^{-n} \in \mathbf{F}[z^{-1}].$$

If $\alpha_n \neq 0$ the n is the degree of a , denoted by ∂a . We define $\partial a = -\infty$ for $a = 0$.

We shall also consider the ring $\mathbf{F}\{z^{-1}\}$ of realizable rational functions over \mathbf{F} , i.e. the ring of elements q/p , where $p, q \in \mathbf{F}[z^{-1}]$ and $(z^{-1}, p) = 1$. They can also be written in the form

$$A = \alpha_0 + \alpha_1 z^{-1} + \alpha_2 z^{-2} + \dots, \quad \alpha_k \in \mathbf{F}.$$

The subset of elements A of $\mathbf{F}\{z^{-1}\}$ for which the sequence $\{\alpha_0, \alpha_1, \alpha_2, \dots\}$ converges to zero forms the ring of stable realizable rational functions over \mathbf{F} and will be denoted by $\mathbf{F}^+\{z^{-1}\}$.

A polynomial $a \in \mathbf{F}[z^{-1}]$ is stable if $1/a \in \mathbf{F}^+\{z^{-1}\}$. Given $a \in \mathbf{F}[z^{-1}]$, we shall consider the factorization

$$a = a^+ a^-,$$

where a^+ is the stable factor of a having highest degree and belonging to $\mathbf{F}[z^{-1}]$. This factorization is unique up to units of $\mathbf{F}[z^{-1}]$, see [2].

If

$$A = \alpha_0 + \alpha_1 z^{-1} + \alpha_2 z^{-2} + \dots \in \mathbf{F}\{z^{-1}\},$$

the norm of A is defined as

$$\|A\| = \sup_{i=0,1,\dots} |\alpha_i|$$

if the supremum exists, otherwise $\|A\| = \infty$.

The quadratic norm of A is defined as

$$\|A\|^2 = |\alpha_0|^2 + |\alpha_1|^2 + |\alpha_2|^2 + \dots$$

Defining

$$\bar{A} = \bar{\alpha}_0 + \bar{\alpha}_1 z + \bar{\alpha}_2 z^2 + \dots,$$

where $\bar{\alpha}_k$ is the complex conjugate of α_k , and

$$\langle A \rangle = \alpha_0,$$

the absolute term of A , we can write

$$\|A\|^2 = \langle \bar{A}A \rangle$$

whenever $A \in \mathbf{F}^+\{z^{-1}\}$.

It is to be noted that both norms are elements of \mathbf{R} , the topologically complete field of reals.

Since $\mathbf{F}[z^{-1}]$ is a subring of $\mathbf{F}\{z^{-1}\}$, the two norms for polynomials are defined analogously.

Further consider a linear Diophantine equation

$$(1) \quad ax + by = c$$

over $\mathbf{F}[z^{-1}]$. It is well-known [2] that this equation has a solution if and only if the greatest common divisor of a and b divides c , which is written as $(a, b) \mid c$. If x_0, y_0 is a particular solution of equation (1) then all solutions x, y are given by

$$x = x_0 + \frac{b}{(a, b)} t,$$

$$y = y_0 - \frac{a}{(a, b)} t,$$

where t is an arbitrary polynomial of $\mathbf{F}[z^{-1}]$. A simple and effective method of finding x_0, y_0 is presented in [2].

In applications we often seek for a particular solution x^0, y^0 such that the degree of one polynomial, say y^0 , is minimal. To obtain the solution we write

$$y_0 = \frac{a}{(a, b)} q_0 + r_0, \quad \partial r_0 < \partial \frac{a}{(a, b)}.$$

Then

$$y = r_0 + \frac{a}{(a, b)} (q_0 - t)$$

and, evidently,

$$x^0 = x_0 + \frac{b}{(a, b)} q_0,$$

$$y^0 = r_0$$

is uniquely determined on setting $t = q_0$.

Example 1. Consider the equation

$$(2) \quad (1 - z^{-1})x + z^{-3}y = 1 + z^{-1} - 2z^{-2} + 1.5z^{-3}$$

over the ring $\mathbf{R}[z^{-1}]$ and find the solution x^0, y^0 satisfying $\partial y^0 = \min$.

The algorithm given in [2] yields

$$\begin{aligned}
 x &= 1 + 2z^{-1} + 0.5z^{-3} - 0.5z^{-4} + 1.5z^{-5} + z^{-3}t, \\
 y &= 1 + z^{-1} - 2z^{-2} + 1.5z^{-3} - (1 - z^{-1})t
 \end{aligned}$$

for any $t \in \mathbf{R}[z^{-1}]$. Since

$$1 + z^{-1} - 2z^{-2} + 1.5z^{-3} = (1 - z^{-1})(-0.5 + 0.5z^{-1} - 1.5z^{-2}) + 1.5,$$

we have

$$\begin{aligned}
 x^0 &= 1 + 2z^{-1}, \\
 y^0 &= 1.5
 \end{aligned}$$

on setting $t = -0.5 + 0.5z^{-1} - 1.5z^{-2}$.

Alternatively, we may wish to find a solution x_e, y_e such that $\partial y_e = \min$ subject to $\|y_e\| \leq \gamma$, where $\gamma \in \mathbf{R}$ is a given bound.

To find the solution we write

$$(3) \quad y = y^0 - \frac{a}{(a, b)} t$$

and let

$$\begin{aligned}
 y &= \eta_0 + \eta_1 z^{-1} + \dots, \\
 y^0 &= \mu_0 + \mu_1 z^{-1} + \dots, \\
 \frac{a}{(a, b)} &= \alpha_0 + \alpha_1 z^{-1} + \dots, \\
 t &= \tau_0 + \tau_1 z^{-1} + \dots.
 \end{aligned}$$

Then (3) yields the finite system of equations

$$\begin{aligned}
 \eta_0 &= \mu_0 - \alpha_0 \tau_0, \\
 \eta_1 &= \mu_1 - \alpha_1 \tau_0 - \alpha_0 \tau_1, \\
 \eta_2 &= \mu_2 - \alpha_2 \tau_0 - \alpha_1 \tau_1 - \alpha_0 \tau_2 \\
 &\dots\dots\dots
 \end{aligned}$$

and we are to find a $t \in \mathbf{F}[z^{-1}]$ with lowest degree that yields

$$(4) \quad |\eta_k| \leq \gamma, \quad k = 0, 1, \dots$$

A systematic procedure to find all such t is given below. First take $t = 0$. Then inequalities (4) read

$$\begin{aligned} |\mu_0| &\leq \gamma, \\ |\mu_1| &\leq \gamma, \\ |\mu_2| &\leq \gamma. \\ &\dots\dots \end{aligned}$$

Should these inequalities be satisfied,

$$\begin{aligned} x_e &= x^0, \\ y_e &= y^0. \end{aligned}$$

This is just a check if the solution x^0, y^0 happens to satisfy (4). If not, increase the degree of t and consider $t = \tau_0$. Then inequalities (4) read

$$\begin{aligned} |\mu_0 - \alpha_0 \tau_0| &\leq \gamma, \\ |\mu_1 - \alpha_1 \tau_0| &\leq \gamma, \\ |\mu_2 - \alpha_2 \tau_0| &\leq \gamma \\ &\dots\dots \end{aligned}$$

and if they admit a solution τ_0 , we have

$$\begin{aligned} x_e &= x^0 + \frac{b}{(a, b)} \tau_0, \\ y_e &= y^0 - \frac{a}{(a, b)} \tau_0. \end{aligned}$$

If they are contradictory, increase the degree of t by one, i.e. consider $t = \tau_0 + \tau_1 z^{-1}$. Then inequalities (4) read

$$\begin{aligned} |\mu_0 - \alpha_0 \tau_0| &\leq \gamma, \\ |\mu_1 - \alpha_1 \tau_0 - \alpha_0 \tau_1| &\leq \gamma, \\ |\mu_2 - \alpha_2 \tau_0 - \alpha_1 \tau_1| &\leq \gamma \\ &\dots\dots \end{aligned}$$

and if they have a solution τ_0, τ_1 , we get

$$\begin{aligned} x_e &= x^0 + \frac{b}{(a, b)} (\tau_0 + \tau_1 z^{-1}) \\ y_e &= y^0 - \frac{a}{(a, b)} (\tau_0 + \tau_1 z^{-1}). \end{aligned}$$

It they are contradictory, again increase the degree of t etc. until we find a solution or infer that no solution exists.

It is obvious that this solution, if it exists, need not be unique.

Example 2. Consider again equation (2) and find all solutions x_e, y_e , such that $\partial y_e = \min$ subject to $\|y_e\| \leq 1$.

We write

$$y = 1.5 - (1 - z^{-1})t.$$

Setting $t = 0$ we obtain $y = 1.5$ and the inequality

$$-1 \leq 1.5 \leq 1$$

is inconsistent. Hence we have to increase the degree of t and take $t = \tau_0$. We obtain

$$y = (1.5 - \tau_0) + \tau_0 z^{-1}$$

and the inequalities

$$-1 \leq 1.5 - \tau_0 \leq 1,$$

$$-1 \leq \tau_0 \leq 1,$$

which have a solution for $0.5 \leq \tau_0 \leq 1$. Therefore, equation (2) has infinitely many solutions

$$x_e = 1 + 2z^{-1} + \tau_0 z^{-3},$$

$$y_e = (1.5 - \tau_0) + \tau_0 z^{-1}, \quad 0.5 \leq \tau_0 \leq 1.$$

The problem of finding a solution x_u, y_u of (1) such that $\partial y_u = \min$ subject to $\|x_u\| \leq \gamma$, where $\gamma \in \mathbf{R}$ is a given bound, is essentially the same. Write

$$(5) \quad x = x^0 + \frac{b}{(a, b)} t$$

and let

$$x = \xi_0 + \xi_1 z^{-1} + \dots,$$

$$x^0 = \lambda_0 + \lambda_1 z^{-1} + \dots,$$

$$\frac{b}{(a, b)} = \beta_0 + \beta_1 z^{-1} + \dots,$$

$$t = \tau_0 + \tau_1 z^{-1} + \dots$$

Then (5) yields the finite system of equations

$$\xi_0 = \lambda_0 + \beta_0 \tau_0,$$

$$\xi_1 = \lambda_1 + \beta_1 \tau_0 + \beta_0 \tau_1,$$

$$\xi_2 = \lambda_2 + \beta_2 \tau_0 + \beta_1 \tau_1 + \beta_0 \tau_2$$

.....

and we are to find a $t \in \mathbf{F}[z^{-1}]$ with lowest degree that yields

$$|\xi_k| \leq \gamma, \quad k = 0, 1, \dots$$

Example 3. Consider equation (2) and find all solutions x_u, y_u such that $\partial y_u = \min$ subject to $\|x_u\| \leq 1$.

We write

$$x = 1 + 2z^{-1} + z^{-3}t.$$

It is seen that $\|x\| \geq 2$ regardless of t and hence no solution x_u, y_u satisfying $\|x_u\| \leq 1$ exists.

A more general problem is that of finding a solution x_u, y_u of (1) such that $\partial y_u = \min$ subject to $\|U\| \leq \gamma$, where $U \in \mathbf{F}^+\{z^{-1}\}$ depends on x_u through two polynomials $u, v \in \mathbf{F}[z^{-1}]$ as

$$U = \frac{u}{v} x_u.$$

In this case we write

$$(6) \quad U = \frac{u}{v} x^0 + \frac{u}{v} \frac{b}{(a, b)} t$$

and let

$$\begin{aligned} U &= \omega_0 + \omega_1 z^{-1} + \dots, \\ \frac{u}{v} x^0 &= \varphi_0 + \varphi_1 z^{-1} + \dots, \\ \frac{u}{v} \frac{b}{(a, b)} &= \varepsilon_0 + \varepsilon_1 z^{-1} + \dots, \\ t &= \tau_0 + \tau_1 z^{-1} + \dots. \end{aligned}$$

Then (6) yields the infinite system of equations

$$\begin{aligned} \omega_0 &= \varphi_0 + \varepsilon_0 \tau_0, \\ \omega_1 &= \varphi_1 + \varepsilon_1 \tau_0 + \varepsilon_0 \tau_1, \\ \omega_2 &= \varphi_2 + \varepsilon_2 \tau_0 + \varepsilon_1 \tau_1 + \varepsilon_0 \tau_2 \\ &\dots \end{aligned}$$

and we are to find a $t \in \mathbf{F}[z^{-1}]$ with lowest degree that gives

$$|\omega_k| \leq \gamma, \quad k = 0, 1, \dots$$

We note that this system of inequalities is actually finite due to the fact that U is a *stable realizable rational function*.

The following solution of (1) is also useful in applications. We want to find a solution x_m, y_m such that $\partial y_m \leq m$ and the quadratic norm of y_m is minimal, $\langle \bar{y}_m y_m \rangle = \min$.

To find this solution, we write

$$(7) \quad y_m = y^0 - wt,$$

where we denoted $w = a/(a, b)$. Now given an integer m we are first to find a t such that $\partial y_m \leq m$. Hence we take

$$t = 0 \quad \text{if} \quad m < \partial w$$

and

$$t = \tau_0 + \tau_1 z^{-1} + \dots + \tau_n z^{-n} \quad \text{if} \quad m = \partial w + n.$$

In the former case we have

$$\begin{aligned} x_m &= x^0, \\ y_m &= y^0, \end{aligned}$$

while in the latter case we have to minimize $\langle \bar{y}_m y_m \rangle$.

In view of (7) we write

$$\begin{aligned} \langle \bar{y}_m y_m \rangle &= \langle \bar{y}^0 y^0 \rangle - \langle \bar{y}^0 wt \rangle - \\ &\quad - \langle \bar{i} \bar{w} y^0 \rangle + \langle \bar{i} \bar{w} wt \rangle. \end{aligned}$$

It is seen that $\langle \bar{y}_m y_m \rangle$ attains its minimum for some t if and only if it attains its minimum for the i . We can write

$$\begin{aligned} \langle \bar{y}_m y_m \rangle &= \langle \bar{y}^0 y^0 \rangle - \langle \bar{y}^0 wt \rangle - \\ &\quad - \langle \bar{w} y^0 \rangle \bar{\tau}_0 - \langle z \bar{w} y^0 \rangle \bar{\tau}_1 - \dots - \langle z^n \bar{w} y^0 \rangle \bar{\tau}_n + \\ &\quad + \langle \bar{w} wt \rangle \bar{\tau}_0 + \langle z \bar{w} wt \rangle \bar{\tau}_1 + \dots + \langle z^n \bar{w} wt \rangle \bar{\tau}_n. \end{aligned}$$

Since the first two terms on the right-hand side above do not depend upon i , the minimum of $\langle \bar{y}_m y_m \rangle$ is evidently attained when

$$\langle z^k \bar{w} wt \rangle = \langle z^k \bar{w} y^0 \rangle, \quad k = 0, 1, \dots, n.$$

This results in the set of simultaneous linear equations

$$(8) \quad \begin{bmatrix} \langle \bar{w} w \rangle & \langle \bar{w} w z^{-1} \rangle & \dots & \langle \bar{w} w z^{-n} \rangle \\ \langle z \bar{w} w \rangle & \langle \bar{w} w \rangle & \dots & \langle \bar{w} w z^{-(n-1)} \rangle \\ \dots & \dots & \dots & \dots \\ \langle z^n \bar{w} w \rangle & \langle z^{n-1} \bar{w} w \rangle & \dots & \langle \bar{w} w \rangle \end{bmatrix} \begin{bmatrix} \tau_0 \\ \tau_1 \\ \vdots \\ \tau_n \end{bmatrix} = \begin{bmatrix} \langle \bar{w} y^0 \rangle \\ \langle z \bar{w} y^0 \rangle \\ \dots \\ \langle z^n \bar{w} y^0 \rangle \end{bmatrix}$$

for $\tau_0, \tau_1, \dots, \tau_n$.

System (8) has always a unique solution because $\langle z^k \bar{w}w \rangle = \langle \overline{w}wz^{-k} \rangle$ and hence the system matrix is nonsingular. We can conclude that there is a unique solution x_m, y_m if and only if $m \geq \hat{\partial}y^0$.

It is obvious from (8) that

$$(9) \quad \langle \bar{y}_{m+1}y_{m+1} \rangle \leq \langle \bar{y}_m y_m \rangle, \quad m \geq \hat{\partial}y^0$$

that is, the greater m is allowed the less quadratic norm can be attained.

Example 4. Consider again equation (2) and find the solutions x_m, y_m satisfying $\hat{\partial}y_m \leq m$ and $\langle \bar{y}_m y_m \rangle = \min, m = 0, 1, 2$.

We write

$$y = 1.5 - (1 - z^{-1})t.$$

Since $w = 1 - z^{-1}$, we get

$$\begin{aligned} \bar{w}w &= (1 - z)(1 - z^{-1}) = -z + 2 - z^{-1}, \\ \bar{w}y^0 &= (1 - z)1.5 = -1.5z + 1.5. \end{aligned}$$

For $m = 0$ we have $m < \hat{\partial}w = 1$ and hence we have to take $t = 0$. Then

$$\begin{aligned} x_0 &= x^0 = 1 + 2z^{-1}, \\ y_0 &= y^0 = 1.5. \end{aligned}$$

For $m = 1$ we have $m = \hat{\partial}w = 1$, i.e. $n = 0$ and we have to take $t = \tau_0$. Then we are to solve the equation

$$2\tau_0 = 1.5$$

yielding $\tau_0 = 0.75$. Therefore,

$$\begin{aligned} x_1 &= 1 + 2z^{-1} + 0.75z^{-3}, \\ y_1 &= 0.75 + 0.75z^{-1}. \end{aligned}$$

For $m = 2$ we obtain $n = 1$, i.e. $t = \tau_0 + \tau_1 z^{-1}$. Equations (8) then become

$$\begin{bmatrix} 2 & -1 \\ -1 & 2 \end{bmatrix} \begin{bmatrix} \tau_0 \\ \tau_1 \end{bmatrix} = \begin{bmatrix} 1.5 \\ 0 \end{bmatrix}$$

and we obtain

$$\begin{aligned} \tau_0 &= 1, \\ \tau_1 &= 0.5. \end{aligned}$$

Hence

$$\begin{aligned} x_2 &= 1 + 2z^{-1} + z^{-3} + 0.5z^{-4}, \\ y_2 &= 0.5 + 0.5z^{-1} + 0.5z^{-2}. \end{aligned}$$

326 To conclude, we compute

$$\langle \bar{y}_0, y_0 \rangle = 2.25 \quad ,$$

$$\langle \bar{y}_1, y_1 \rangle = 1.125 \quad ,$$

$$\langle \bar{y}_2, y_2 \rangle = 0.75 \quad .$$

and relation (9) holds, indeed.

A more general problem calls for finding a solution x_m, y_m such that $\partial y_m \leq m$ and $\langle \bar{y}_m, y_m \rangle = \min$ where $V = \bar{u}u$ and the $u \in \mathbf{F}[z^{-1}]$ is a "weighting" polynomial. Going through the derivation of (8) we conclude that we have just to replace w by uw and y^0 by uy^0 throughout to solve the problem.

SYSTEM DESCRIPTION

By a system we shall mean a finite dimensional, linear, discrete, single-input, single-output system over a field \mathbf{F} , which is a subfield of the field of complex numbers. The precise definition is given in [2], [5]. Such a system can be described by the dynamical equations

$$\mathbf{x}_{k+1} = \mathbf{A}\mathbf{x}_k + \mathbf{B}\mathbf{u}_k$$

$$\mathbf{y}_k = \mathbf{C}\mathbf{x}_k + \mathbf{D}\mathbf{u}_k \quad ,$$

where \mathbf{x} is an n -dimensional state vector, \mathbf{u} is the input, \mathbf{y} is the output, and k is an integer. The \mathbf{A} , \mathbf{B} , \mathbf{C} , and \mathbf{D} are matrices of appropriate dimensions defined over the field \mathbf{F} .

The rational function

$$S = \mathbf{C}z^{-1}(\mathbf{I}_n - z^{-1}\mathbf{A})^{-1}\mathbf{B} + \mathbf{D} \in \mathbf{F}\{z^{-1}\}$$

is called the transfer function of the system. On the other hand, any system whose transfer function is S is called a realization of S . It is apparent that there are many realizations of S . The one having lowest dimensional state vector is called a minimal realization. It is well-known [1], [5] that there is a one-to-one correspondence between S and its realization if and only if the realization is minimal. Otherwise speaking, nonminimal realizations contain certain parts which have no relation to S .

By definition, the S can be written as the ratio of two polynomials of $\mathbf{F}[z^{-1}]$,

$$S = \frac{b}{a} \quad ,$$

that satisfy

$$(a, b) = 1 \quad ,$$

$$(a, z^{-1}) = 1 \quad .$$

The polynomial $\det(\mathbf{I}_n - z^{-1}\mathbf{A})$ is called the pseudocharacteristic polynomial [5] of the system. Hence a is the pseudocharacteristic polynomial of the minimal realization of S . In a previous work [2], [3], [4] the a has been called the annihilating polynomial of the system.

It can be shown [5] that a system is stable if and only if its pseudocharacteristic polynomial is stable.

Inasmuch as the reference sequence may also be viewed as a response of a system with transfer function W excited by a unit pulse input, we identify the reference sequence with the ratio of two polynomials of $\mathbf{F}[z^{-1}]$,

$$W = \frac{q}{p},$$

where

$$(p, q) = 1,$$

$$(p, z^{-1}) = 1.$$

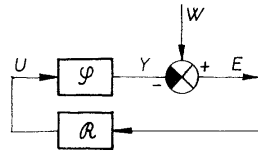

Fig. 1. Closed-Loop System.

In synthesizing closed-loop systems the crucial step is to make the system stable. Since the closed-loop system shown in Fig. 1, consisting of a system \mathcal{S} to be controlled and a controller \mathcal{R} , need not be a minimal realization of its transfer function K relating Y to W ,

$$K = \frac{SR}{1 + SR},$$

the K must satisfy certain additional conditions in order to yield a stable system. It has been proved in [5] that the closed-loop system, where \mathcal{S} and \mathcal{R} are minimal realizations of $S = b/a$ and $R = s/r$, respectively, is stable if and only if K can be written in the form

$$K = bM, \quad 1 - K = aN,$$

where M, N are elements of $\mathbf{F}^+\{z^{-1}\}$ that obey the linear Diophantine equation

$$bM + aN = 1.$$

The freedom in choosing M and N can be utilized for optimization.

The minimum time control problems without any constraints have been considered in [3], [4], [5]. We shall summarize both formulation and solution of the problems in order to obtain a basis for our future investigations.

We are given either the open-loop control system configuration shown in Fig. 2, where \mathcal{S} is a (not necessarily minimal) realization of $S = b/a$ and $W = q/p$ is the

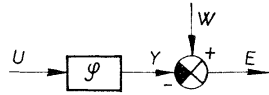

Fig. 2. Open-Loop Control.

reference input sequence; or we are given the closed-loop control system configuration shown in Fig. 1, where \mathcal{S} is a minimal realization of $S = b/a$ and $W = q/p$ is the reference input sequence.

Since the closed control loop must contain a delay of at least one time unit to be physically realizable, we shall agree on incorporating this delay into the system to be controlled by assuming that $\mathbf{D} = \mathbf{0}$ or equivalently $z^{-1} | b$. This assumption is unnecessary for the open-loop control problems.

For convenience, let

$$(a, p) = d, \quad a = a_0 d, \\ p = d p_0.$$

Then we can consider the minimum time control problems of the following four types.

- (10) Given the open-loop configuration, find a stable control sequence U so as to zero the error E in a minimum time k_{\min}^0 and thereafter.
- (11) Given the open-loop configuration, find a finite control sequence U so as to zero the error E in a minimum time k_{\min}^0 and thereafter.
- (12) Given the closed-loop configuration, find a controller \mathcal{R} of minimal realization such that the closed-loop system is stable, the control sequence U is stable, and the error E vanishes in a minimum time k_{\min}^0 and thereafter.
- (13) Given the closed-loop configuration, find a controller \mathcal{R} of minimal realization such that the closed-loop system is stable, the control sequence U is finite, and the error E vanishes in a minimum time k_{\min}^0 and thereafter.

The solution of all the above problems is given below.

Theorem 1. Problem (10) has a solution if and only if p_0 is stable. The control is unique and it is given as 329

$$U = \frac{a_0 x^0}{p_0 b^+},$$

where x^0, y^0 is such solution of the Diophantine equation

$$(14) \quad b^- x + p y = q$$

that

$$\partial y^0 = \min.$$

Proof. Write

$$E = W - S U = \frac{q}{p} - \frac{b}{a} U.$$

Since the error is to vanish in a finite time, E must be a polynomial, say y . Therefore

$$(15) \quad y = \frac{q}{p} - \frac{b}{a} U = \frac{a_0 q - p_0 b U}{a_0 p}.$$

But E is to vanish in a minimum time and hence y must be a polynomial of lowest degree. To reduce the degree of y as much as possible and yet preserve a stable U , we have to set

$$(16) \quad U = \frac{a_0 x}{p_0 b^+},$$

where x is a polynomial to be specified. In view of (16) the expression (15) is equivalent to equation (14), which is to be solved for x^0, y^0 such that $\partial y^0 = \min$. Then

$$k_{\min} = 1 + \partial y^0 \quad \text{if } y^0 \neq 0 \quad \text{and} \quad k_{\min} = 0 \quad \text{otherwise.}$$

It is seen that U is stable if and only if p_0 is stable. Then $(b^-, p) = 1$ and, in turn, equation (14) has always a solution. □

Example 5. Consider a system to be controlled given by

$$(17) \quad S = 0.25 \frac{z^{-1}(z^{-1} - 2)}{1 - z^{-1}}$$

over the field \mathbf{R} and solve problem (10) for the reference sequence

$$(18) \quad W = 0.5 \frac{1 + z^{-1}}{1 - z^{-1}}.$$

330 Equation (14) reads

$$0.25z^{-1}x + (1 - z^{-1})y = 0.5 + 0.5z^{-1}$$

and has the solution

$$x = 2 + 2z^{-1} + (1 - z^{-1})t,$$

$$y = 0.5 + 0.5z^{-1} - 0.25z^{-1}t$$

for any $t \in \mathbf{R}[z^{-1}]$. The solution x^0, y^0 satisfying $\partial y^0 = \min$ becomes

$$x^0 = 4,$$

$$y^0 = 0.5$$

and hence the optimal control sequence

$$U = \frac{4}{z^{-1} - 2}$$

gives $E = 0.5$, $k_{\min}^0 = 1$.

Theorem 2. *Problem (11) has a solution if and only if $p \mid a$. The control is unique and is given by*

$$U = a_0 x^0,$$

where x^0, y^0 is such solution of the Diophantine equation

$$(19) \quad bx + py = q$$

that

$$\partial y^0 = \min.$$

Proof. Write

$$E = W - SU = \frac{q}{p} - \frac{b}{a}U.$$

Since the error is to vanish in a finite time, E must be a polynomial, say y . Therefore

$$(20) \quad y = \frac{q}{p} - \frac{b}{a}U = \frac{a_0q - p_0bU}{a_0p}.$$

But E is to vanish in a minimum time and hence y must be a polynomial of lowest degree. To reduce the degree of y as much as possible and yet preserve a polynomial U , we have to set

$$U = \frac{a_0x}{p_0},$$

where x is a polynomial unspecified as yet but $p_0 \mid x$. Then (20) is equivalent to equation (19), which is to be solved for x^0, y^0 such that $\partial y^0 = \min$. Then $k_{\min}^0 = 1 + \partial y^0$ if $y_0 \neq 0$ and $k_{\min}^0 = 0$ otherwise.

Since $p_0 \mid x$ and $p_0 \mid p$, equation (19) can have a solution only if $p_0 \mid q$, i.e. p_0 must be a unit of $\mathbf{F}[z^{-1}]$. Otherwise speaking, $p \mid a$. \square

Example 6. Consider again a system given by (17) and solve problem (11) for the reference sequence (18).

Equation (19) reads

$$0.25z^{-1}(z^{-1} - 2)x + (1 - z^{-1})y = 0.5 + 0.5z^{-1}$$

and its general solution is

$$x = -2 - 2z^{-1} + (1 - z^{-1})t,$$

$$y = 0.5 - 0.5z^{-2} - 0.25z^{-1}(z^{-1} - 2)t$$

for an arbitrary $t \in \mathbf{R}[z^{-1}]$.

The solution

$$x^0 = -4,$$

$$y^0 = 0.5 - z^{-1}$$

satisfies $\partial y^0 = \min$ and, therefore, the optimal control sequence

$$U = -4$$

gives $E = 0.5 - z^{-1}$, $k_{\min}^0 = 2$.

Theorem 3. *Problem (12) has a solution if and only if p_0 is stable. The controller is unique and is given as a minimal realization of*

$$R = \frac{a_0^+ x^0}{p_0 b^+ y^0},$$

where x^0, y^0 is such solution of the Diophantine equation

$$(21) \quad b^- x + a_0^- p y = q^+$$

for which

$$\partial y^0 = \min.$$

Proof. Write

$$E = W - Y = (1 - K)W.$$

To guarantee the closed-loop stability we have to set $1 - K = aN$ for some $N \in \mathbf{F}^+\{z^{-1}\}$. Hence

$$E = aN \frac{q}{p} = a_0 N \frac{q}{p_0}.$$

As the error is to vanish in a minimum time, E must be a polynomial of minimum degree. Therefore

$$(22) \quad N = \frac{p_0 y}{a_0^+ q^+},$$

where y is a polynomial to be specified later. It follows that

$$(23) \quad E = a_0^- q^- y.$$

Using the other stability condition $K = bM$ for some $M \in \mathbf{F}^+\{z^{-1}\}$, we have

$$E = W - Y = W - KW = \frac{q}{p} - bM \frac{q}{p},$$

or equivalently

$$pE = q - bMq.$$

The E is a polynomial of minimum degree whenever pE , and in turn also bMq , is so. Hence we have to take

$$(24) \quad M = \frac{x}{b^+ q^+},$$

where x is an unspecified polynomial as yet.

Substituting (24) and (23) into the stability equation

$$bM + aN = 1,$$

we end up with equation (21) coupling the x and y . In view of (23) the equation should be solved for x^0, y^0 such that $\partial y^0 = \min$. Then $k_{\min}^0 = 1 + \partial a_0^- + \partial q^- + \partial y^0$.

The controller is given as a minimal realization of

$$R = \frac{1}{S} \frac{K}{1 - K} = \frac{M}{N} = \frac{a_0^+ x^0}{p_0 b^+ y^0}$$

and

$$U = RE = \frac{a_0 q^- x^0}{p_0 b^+}.$$

The U is stable if and only if p_0 is stable. This condition implies $(b^-, a_0^- p) = 1$ and hence equation (21) has always a solution. \square

Example 7. Consider the system that is a minimal realization of (17) and solve problem (12) for the reference sequence (18).

Equation (21) reads

$$0.25z^{-1}x + (1 - z^{-1})y = 1$$

and its general solution becomes

$$x = 4 + (1 - z^{-1})t$$

$$y = 1 - 0.25z^{-1}t$$

for any $t \in \mathbf{R}[z^{-1}]$.

The required solution satisfying $\hat{\rho}y^0 = \min$ is

$$x^0 = 4$$

$$y^0 = 1$$

and hence the optimal controller is a minimal realization of

$$R = \frac{4}{z^{-1} - 2}$$

and

$$U = 2 \frac{1 + z^{-1}}{z^{-1} - 2}, \quad E = 0.5 + 0.5z^{-1}, \quad k_{\min}^0 = 2.$$

Theorem 4. *Problem (13) has a solution if and only if $p \mid a$. The controller is unique and is given as a minimal realization of*

$$R = \frac{a_0^+ x^0}{y^0},$$

where x^0, y^0 is such solution of the Diophantine equation

$$(25) \quad bx + a_0^- py = q^+$$

for which

$$\hat{\rho}y^0 = \min.$$

Proof. Write

$$E = W - Y = (1 - K)W.$$

To guarantee the closed-loop stability we have to set $1 - K = aN$ for some $N \in \mathbf{F}^+\{z^{-1}\}$. Since the error is to vanish in a minimum time, E must be a polynomial of minimum degree. Therefore

$$(26) \quad N = \frac{p_0 y}{a_0^+ q^+},$$

where x is a polynomial to be specified later. It follows that

$$(27) \quad E = a_0^- q^- y.$$

334 Using the other stability condition $K = bM$ for some $M \in \mathbf{F}^+\{z^{-1}\}$, we obtain

$$E = W - Y = W - KW = \frac{q}{p} - bM \frac{q}{p},$$

or equivalently

$$pE = q - bMq.$$

The E is a polynomial of minimum degree whenever pE , and in turn also bMq , is so. As U must be a polynomial, we have to take

$$(28) \quad M = \frac{x}{q^+}$$

where x is an unspecified polynomial as yet.

Substituting (28) and (26) into the stability equation

$$bM + aN = 1,$$

we eventually obtain equation (25) coupling the x and y . In view of (27) the equation is to be solved for x^0, y^0 such that $\partial y^0 = \min$. Then $k_{\min}^0 = 1 + \partial a_0^- + \partial q^- + \partial y^0$.

The controller is given as a minimal realization of

$$R = \frac{1}{S} \frac{K}{1-K} = \frac{M}{N} = \frac{a_0^+ x^0}{p_0 y^0}$$

and

$$U = RE = \frac{a_0 q^- x^0}{p_0}.$$

It is seen that U is a polynomial if and only if $p_0 \mid x$. Then equation (25) can have a solution only if $p_0 \mid q^+$, i.e. p_0 must be a unit of $\mathbf{F}[z^{-1}]$. Otherwise speaking, $p \mid a$. \square

Example 8. Consider the system that is a minimal realization of (17) and solve problem (13) for the reference signal (18).

Equation (25) becomes

$$0.25z^{-1}(z^{-1} - 2)x + (1 - z^{-1})y = 1$$

and its general solution is

$$x = -4 + (1 - z^{-1})t,$$

$$y = 1 - z^{-1} - 0.25z^{-1}(z^{-1} - 2)t$$

for arbitrary $t \in \mathbf{R}[z^{-1}]$.

The particular solution satisfying $\partial y^0 = \min$ reads

$$\begin{aligned}x^0 &= -4, \\y^0 &= 1 - z^{-1}\end{aligned}$$

and it yields the optimal controller as a minimal realization of

$$R = -\frac{4}{1 - z^{-1}};$$

moreover,

$$U = -2 - 2z^{-1}, \quad E = 0.5 - 0.5z^{-2}, \quad k_{\min}^0 = 3.$$

CONSTRAINED MINIMUM TIME CONTROLS

In this section we shall deal with the minimum time control problems with various constraints. It is more realistic to consider constraints on control or error sequences because of limitations in the system to be controlled or the controller itself.

There are four basic problems to be defined below, each in three modifications denoted by (a), (b), or (c).

- (29) Given the open-loop configuration, find a stable control sequence U so as to make the error E vanish
- in a minimum time k_{\min} and thereafter subject to $\|U\| \leq \gamma$;
 - in a minimum time k_{\min} and thereafter subject to $\|E\| \leq \gamma$;
 - in a given time $l \geq k_{\min}^0$ and thereafter while minimizing $\langle \bar{E}E \rangle$.
- (30) Given the open-loop configuration, find a finite control sequence U so as to make the error E vanish
- in a minimum time k_{\min} and thereafter subject to $\|U\| \leq \gamma$;
 - in a minimum time k_{\min} and thereafter subject to $\|E\| \leq \gamma$;
 - in a given time $l \geq k_{\min}^0$ and thereafter while minimizing $\langle \bar{E}E \rangle$.
- (31) Given the closed-loop configuration, find a controller \mathcal{R} of minimal realization such that the closed-loop system is stable, the control U is stable and the error E vanishes
- in a minimum time k_{\min} and thereafter subject to $\|U\| \leq \gamma$;
 - in a minimum time k_{\min} and thereafter subject to $\|E\| \leq \gamma$;
 - in a finite time $l \geq k_{\min}^0$ and thereafter while $\langle \bar{E}E \rangle$ is minimized.
- (32) Given the closed-loop configuration, find a controller \mathcal{R} of minimal realization such that the closed-loop system is stable, the control U is finite and the error E vanishes
- in a minimum time k_{\min} and thereafter subject to $\|U\| \leq \gamma$;
 - in a minimum time k_{\min} and thereafter subject to $\|E\| \leq \gamma$;
 - in a given time $l \geq k_{\min}^0$ and thereafter while $\langle \bar{E}E \rangle$ is minimized.

Constraints of the type (a) are motivated by the desire to avoid too large control inputs to the system, while constraints (b) are designed to limit too large transient errors. In both problems the bound γ is prespecified and the required limitation is achieved at the expense of the control time. Apparently, $k_{\min} \geq k_{\min}^0$. Constraint (c) is an alternate way to bound the error. Instead of specifying a bound γ , we specify an acceptable control time $l \geq k_{\min}^0$ and limit the error indirectly by minimizing its quadratic norm. This approach was first taken by Peterka in [6]; our solution, however, is slightly different and computationally superior.

The solution of the above control problems is given in the following theorems.

Theorem 5. *Problem (29) has a solution if and only if*

sub (a) p_0 is stable and the Diophantine equation (14) has a solution x_u, y_u such that $\hat{\partial}y_u = \min$ subject to

$$\left\| \frac{a_0}{p_0 b^+} x_u \right\| \leq \gamma;$$

sub (b) p_0 is stable and the Diophantine equation (14) has a solution x_e, y_e such that

$$\hat{\partial}y_e = \min \text{ subject to } \|y_e\| \leq \gamma;$$

sub (c) p_0 is stable.

The optimal control is

sub (a) not unique, in general, and is given by

$$U = \frac{a_0 x_u}{p_0 b^+};$$

sub (b) not unique, in general, and is given by

$$U = \frac{a_0 x_e}{p_0 b^+};$$

sub (c) unique and is given by

$$U = \frac{a_0 x_m}{p_0 b^+},$$

where x_m, y_m is such solution of equation (14) that

$$\hat{\partial}y_m \leq m = l - 1 \quad \text{and} \quad \langle \bar{y}_m, y_m \rangle = \min.$$

Proof. Following the proof of Theorem 1 we conclude that the error E vanishes in a finite time and thereafter by application of a stable control if and only if

$$E = y$$

and

$$U = \frac{a_0 x}{p_0 b^+},$$

where x, y is a solution of equation (14).

In Theorem 1 we have taken the solution x^0, y^0 satisfying $\partial y^0 = \min$ to make E vanish in a minimum time. In the presence of a constraint we just have to take another appropriate solution. In fact, constraint (a) calls for taking a solution x_u, y_u satisfying $\partial y_u = \min$ subject to $\|U\| \leq \gamma$, constraint (b) calls for taking a solution x_e, y_e satisfying $\partial y_e = \min$ subject to $\|E\| \leq \gamma$, while constraint (c) calls for the solution x_m, y_m satisfying $1 + \partial y_m \leq 1 + m = l$ and $\langle \bar{y}_m, y_m \rangle = \min$. It means that $w = b^-$ in (8).

The existence of the above solutions has been discussed in the Preliminaries. \square

Example 9. Consider again the system to be controlled given by

$$(33) \quad S = 0.25 \frac{z^{-1}(z^{-1} - 2)}{1 - z^{-1}}$$

over \mathbf{R} and solve problem (29) for the reference sequence

$$(34) \quad W = 0.5 \frac{1 + z^{-1}}{1 - z^{-1}}.$$

Equation (14) becomes

$$0.25z^{-1}x + (1 - z^{-1})y = 0.5 + 0.5z^{-1}$$

and has the general solution

$$\begin{aligned} x &= 4 + (1 - z^{-1})t, \\ y &= 0.5 - 0.5z^{-1}t. \end{aligned}$$

Then

$$U = \frac{x}{z^{-1} - 2}, \quad E = y,$$

where $x^0 = 4, y^0 = 0.5$ yields the solution of the associated unconstrained control problem (10)

(a) Consider the control constraint $\|U\| \leq 1$.

Applying the procedure discussed in the Preliminaries, we first choose $t = 0$. Then

$$U = \frac{4}{z^{-1} - 2} = -2 - z^{-1} - 0.5z^{-2} \dots$$

and hence the unconstrained solution is unacceptable.

Taking $t = \tau_0$, we obtain $x = (4 + \tau_0) - \tau_0 z^{-1}$ and

$$U = -\frac{4 + \tau_0}{2} - \frac{4 - \tau_0}{4} z^{-1} - \frac{4 - \tau_0}{8} z^{-2} - \dots$$

Thus we are to satisfy the inequalities

$$-2 \leq -4 - \tau_0 \leq 2,$$

$$-4 \leq -4 + \tau_0 \leq 4,$$

(the other inequalities are implied by the second inequality above), which is impossible.

Taking $t = \tau_0 + \tau_1 z^{-1}$, we have $x = (4 + \tau_0) + (\tau_1 - \tau_0) z^{-1} - \tau_1 z^{-2}$ and

$$U = -\frac{4 + \tau_0}{2} - \frac{4 - \tau_0 + 2\tau_1}{4} z^{-1} - \frac{4 - \tau_0 - 2\tau_1}{8} z^{-2} - \frac{4 - \tau_0 - 2\tau_1}{16} z^{-3} - \dots$$

and the inequalities

$$-2 \leq -4 - \tau_0 \leq 2,$$

$$-4 \leq -4 + \tau_0 - 2\tau_1 \leq 4,$$

$$-8 \leq -4 + \tau_0 + 2\tau_1 \leq 8,$$

which have the unique solution $\tau_0 = -2$, $\tau_1 = -1$. Thus the optimal control is

$$U = \frac{2 + z^{-1} + z^{-2}}{z^{-1} - 2} = -1 - z^{-1} - z^{-2} - 0.5z^{-3} - 0.25z^{-4} - \dots$$

and

$$E = 0.5 + 0.5z^{-1} + 0.25z^{-2}, \quad k_{\min} = 3.$$

(b) Consider the error constraint $\|E\| \leq 0.5$

Applying a similar procedure, we first take $t = 0$. Then

$$E = 0.5$$

and hence the unconstrained optimal control

$$U = \frac{4}{z^{-1} - 2}$$

produces an error satisfying our constraint.

(c) Consider $l = 2$ and minimize $\langle \bar{E}E \rangle$. This problem may be motivated by the desire to decrease the control time in (a), even if the norm of U should slightly exceed unity.

We compute $m = l - 1 = 1$ and since $\partial b^- = 1$, we have to take $n = 0$, i.e. consider $t = \tau_0$. Computing

$$\bar{b}^- b^- = \frac{1}{16},$$

$$\bar{b}^- y^0 = \frac{1}{8} z^{-1},$$

equation (8) reads

$$\frac{1}{16}\tau_0 = 0,$$

i.e. $\tau_0 = 0$. Hence the unconstrained solution

$$U = \frac{4}{z^{-1} - 2}, \quad E = 0.5, \quad k_{\min} = 1 \leq l, \quad \langle \bar{E}E \rangle = 0.25$$

is also the optimal solution of this constrained control problem.

Theorem 6. *Problem (30) has a solution if and only if*

sub (a) $p \mid a$ and the Diophantine equation (19) has a solution x_u, y_u such that $\partial y_u = \min$ subject to $\|a_0 x_u\| \leq \gamma$;

sub (b) $p \mid a$ and the Diophantine equation (19) has a solution x_e, y_e such that $\partial y_e = \min$ subject to $\|y_e\| \leq \gamma$;

sub (c) $p \mid a$.

The optimal control is

sub (a) *not unique, in general, and is given by*

$$U = a_0 x_u;$$

sub (b) *not unique, in general, and is given by*

$$U = a_0 x_e;$$

sub (c) *unique and is given as*

$$U = a_0 x_m,$$

where x_m, y_m is the solution of equation (19) satisfying

$$\partial y_m \leq m = l - 1 \quad \text{and} \quad \langle \bar{y}_m y_m \rangle = \min.$$

Proof. Inspecting the proof of Theorem 2 we conclude that the error E vanishes in a finite time and thereafter by application of a finite control if and only if

$$E = y$$

and

$$U = a_0 x,$$

where x, y is a solution of equation (19).

Now constraint (a) necessitates a solution x_u, y_u satisfying $\partial y_u = \min$ subject to $\|U\| \leq \gamma$, constraint (b) necessitates a solution x_e, y_e such that $\partial y_e = \min$ subject to $\|E\| \leq \gamma$, while constraint (c) necessitates the solution x_m, y_m satisfying $1 + \partial y_m \leq 1 + m = l$ and $\langle \bar{y}_m y_m \rangle = \min$. It means that $w = b$ in (8). \square

340 **Example 10.** Consider again a realization of (33) and solve problem (30) for the reference signal (34).

Equation (19) becomes

$$0.25z^{-1}(z^{-1} - 2)x + (1 - z^{-1})y = 0.5 + 0.5z^{-1}$$

and it has the general solution

$$\begin{aligned} x &= -4 + (1 - z^{-1})t, \\ y &= 0.5 - z^{-1} - 0.25z^{-1}(z^{-1} - 2)t. \end{aligned}$$

Then

$$U = x, \quad E = y,$$

where $x^0 = -4$, $y^0 = 0.5 - z^{-1}$ yields the solution of the associated unconstrained control problem (11).

(a) Consider the control constraint $\|U\| \leq 1$.

Applying the minimizing procedure, we first set $t = 0$. Then

$$U = -4$$

and hence the unconstrained solution is not acceptable. Taking $t = \tau_0$, we obtain

$$U = (\tau_0 - 4) - \tau_0 z^{-1},$$

which yields inequalities

$$\begin{aligned} -1 &\leq \tau_0 - 4 \leq 1, \\ -1 &\leq -\tau_0 \leq 1. \end{aligned}$$

They are not compatible and hence we have to increase the degree of t by one and take $t = \tau_0 + \tau_1 z^{-1}$. Then

$$U = (\tau_0 - 4) + (\tau_1 - \tau_0)z^{-1} - \tau_1 z^{-2}$$

and the inequalities

$$\begin{aligned} -1 &\leq \tau_0 - 4 \leq 1, \\ -1 &\leq \tau_1 - \tau_0 \leq 1, \\ -1 &\leq -\tau_1 \leq 1 \end{aligned}$$

are again incompatible.

Taking further $t = \tau_0 + \tau_1 z^{-1} + \tau_2 z^{-2}$, we have

$$U = (\tau_0 - 4) + (\tau_1 - \tau_0)z^{-1} + (\tau_2 - \tau_1)z^{-2} - \tau_2 z^{-3}$$

and the inequalities

$$\begin{aligned} -1 &\leq \tau_0 - 4 \leq 1, \\ -1 &\leq \tau_1 - \tau_0 \leq 1, \\ -1 &\leq \tau_2 - \tau_1 \leq 1, \\ -1 &\leq -\tau_2 \leq 1 \end{aligned}$$

have the unique solution

$$\tau_0 = 3, \quad \tau_1 = 2, \quad \tau_2 = 1.$$

Therefore the optimal control becomes

$$U = -1 - z^{-1} - z^{-2} - z^{-3}$$

and

$$E = 0.5 + 0.5z^{-1} + 0.25z^{-2} - 0.25z^{-3}, \quad k_{\min} = 4.$$

(b) Consider the error constraint $\|E\| \leq 0.5$.

Applying a similar procedure, we first choose $l = 0$. Then

$$E = 0.5 - z^{-1}$$

and it is seen that it does not satisfy our constraint.

Taking $l = \tau_0$, we obtain

$$E = 0.5 + (0.5\tau_0 - 1)z^{-1} - 0.25\tau_0z^{-2}$$

and the inequalities

$$\begin{aligned} -0.5 &\leq 0.5 && \leq 0.5, \\ -0.5 &\leq 0.5\tau_0 - 1 && \leq 0.5, \\ -0.5 &\leq -0.25\tau_0 && \leq 0.5 \end{aligned}$$

have the solution $1 \leq \tau_0 \leq 2$. Therefore, the optimal control becomes

$$U = (\tau_0 - 4) - \tau_0z^{-1}, \quad 1 \leq \tau_0 \leq 2$$

and

$$E = 0.5 + (0.5\tau_0 - 1)z^{-1} - 0.25\tau_0z^{-2}, \quad k_{\min} = 3.$$

(c) Consider $l = 3$ and minimize $\langle \bar{E}E \rangle$. This problem may be motivated by the desire to simplify problem (b) by solving a simple equation instead of a system of inequalities.

We compute $m = l - 1 = 2$ and since $\partial b = 2$, we have to take $n = 0$, i.e. $l = \tau_0$.

Computing

$$\begin{aligned} \bar{b}b &= -\frac{1}{8}z + \frac{5}{16} - \frac{1}{8}z^{-1}, \\ \bar{b}y^0 &= \frac{1}{8}z^2 - \frac{1}{2}z + \frac{1}{2}, \end{aligned}$$

342 equation (8) becomes

$$\frac{5}{16}\tau_0 = \frac{1}{2};$$

hence $\tau_0 = \frac{8}{5}$ and the optimal control

$$U = 2.4 - 1.6z^{-1}$$

produces

$$E = 0.5 - 0.2z^{-1} - 0.4z^{-2}, \quad k_{\min} = 3 \leq 1, \quad \langle \bar{E}E \rangle = 0.45.$$

Theorem 7. *Problem (31) has a solution if and only if*

sub (a) p_0 is stable and the Diophantine equation (21) has a solution x_u, y_u such that $\partial y_u = \min$ subject to

$$\left\| \frac{a_0 q^-}{p_0 b^+} x_u \right\| \leq \gamma;$$

sub (b) p_0 is stable and the Diophantine equation (21) has a solution x_e, y_e such that $\partial y_e = \min$ subject to $\|a_0^- q^- y_e\| \leq \gamma$;

sub (c) p_0 is stable.

The optimal controller is given as a minimal realization of

sub (a)

$$R = \frac{a_0^+ x_u}{p_0 b^+ y_u}$$

and it is not unique, in general;

sub (b)

$$R = \frac{a_0^+ x_e}{p_0 b^+ y_e}$$

and it is not unique, in general;

sub (c)

$$R = \frac{a_0^+ x_m}{p_0 b^+ y_m}$$

and it is unique. Here x_m, y_m is the solution of equation (21) that satisfies $\partial y_m \leq m = l - 1 - \partial a_0^- - \partial q^-$ and $\langle \bar{y}_m V y_m \rangle = \min$, where

$$V = \bar{q}^- a_0^- \cdot a_0^- q^-.$$

Proof. Inspecting the proof of Theorem 3 we conclude that we have to take

$$R = \frac{a_0^+ x}{p_0 b^+ y}, \quad E = a_0^- q^- y, \quad U = \frac{a_0 q^-}{p_0 b^+} x,$$

where x, y is a solution of equation (21), in order to obtain a stable closed-loop system, a stable control sequence, and an error vanishing in a finite time and thereafter.

Now constraint (a) calls for a solution x_u, y_u , satisfying $\partial y_u = \min$ subject to $\|U\| \leq \gamma$; constraint (b) calls for a solution x_e, y_e satisfying $\partial y_e = \min$ subject to $\|E\| \leq \gamma$, and constraint (c) calls for the solution x_m, y_m satisfying $1 + \partial a_0^- q^- y_m \leq 1 + \partial a_0^- + \partial q^- + m = l$ and $\langle \bar{y}_m, V y_m \rangle = \min$, where $V = \bar{q}^- a_0^- \cdot a_0^- q^-$. We have $w = b^-$ in (8) and $u = a_0^- q^-$.

The existence of the above solutions has been discussed in the Preliminaries. \square

Example 11. Consider again a minimal realization of (33) and solve problem (31) for the reference sequence (34).

Equation (21) becomes

$$0.25z^{-1}x + (1 - z^{-1})y = 1$$

and has the general solution

$$x = 4 + (1 - z^{-1})t,$$

$$y = 1 - 0.25z^{-1}t,$$

for any $t \in \mathbf{R}[z^{-1}]$. Then

$$R = \frac{x}{(z^{-1} - 2)y}, \quad U = 0.5 \frac{1 + z^{-1}}{z^{-1} - 2} x, \quad E = 0.5(1 + z^{-1})y$$

and the solution $x^0 = 4, y^0 = 1$ yields the optimal controller for the associated unconstrained control problem.

(a) Consider the control constraint $\|U\| \leq 1$.

Applying the minimizing procedure, we first try $t = 0$. Then $x = 4$ and

$$U = 2 \frac{1 + z^{-1}}{z^{-1} - 2} = -1 - 1.5z^{-1} - 0.75z^{-2} - \dots$$

is unacceptable.

Taking $t = \tau_0$, we obtain $x = (4 + \tau_0) - \tau_0 z^{-1}$ and

$$U = -\frac{4 + \tau_0}{4} - \frac{12 + \tau_0}{8} z^{-1} - \frac{12 - 3\tau_0}{16} z^{-2} - \frac{12 - 3\tau_0}{32} z^{-3} - \dots$$

We are to satisfy the inequalities

$$-4 \leq -4 - \tau_0 \leq 4,$$

$$-8 \leq -12 - \tau_0 \leq 8,$$

$$-16 \leq -12 + 3\tau_0 \leq 16,$$

which is impossible.

344 Taking further $t = \tau_0 + \tau_1 z^{-1}$, we obtain $x = (4 + \tau_0) + (\tau_1 - \tau_0) z^{-1} - \tau_1 z^{-2}$ and

$$(35) \quad U = -\frac{4 + \tau_0}{4} - \frac{12 + \tau_0 + 2\tau_1}{8} z^{-1} - \frac{12 - 3\tau_0 + 2\tau_1}{16} z^{-2} - \frac{12 - 3\tau_0 - 6\tau_1}{32} z^{-3} - \frac{12 - 3\tau_0 - 6\tau_1}{64} z^{-4} - \dots$$

yields the inequalities

$$\begin{aligned} -4 &\leq -4 - \tau_0 && \leq 4, \\ -8 &\leq -12 - \tau_0 - 2\tau_1 && \leq 8, \\ -16 &\leq -12 + 3\tau_0 - 2\tau_1 && \leq 16, \\ -32 &\leq -12 + 3\tau_0 + 6\tau_1 && \leq 32, \end{aligned}$$

which have infinitely many solutions

$$(36) \quad \begin{aligned} \tau_0 &\leq 0, \\ 3\tau_0 + 6\tau_1 &\leq -20, \\ \tau_0 + 2\tau_1 &\leq -4, \\ 3\tau_0 - 2\tau_1 &\leq -4 \end{aligned}$$

depicted in Fig. 3.

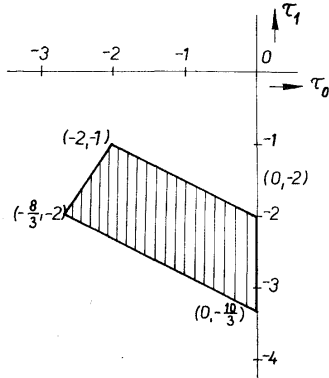

Fig. 3. Solutions τ_0, τ_1 given in (36).

Therefore, the optimal controller is not unique and it is given as a minimal realization of

345

$$R = \frac{(4 + \tau_0) + (\tau_1 - \tau_0)z^{-1} - \tau_1 z^{-2}}{(z^{-1} - 2)(1 - 0.25\tau_0 z^{-1} - 0.25\tau_1 z^{-2})},$$

while U is given by (35), with τ_0, τ_1 satisfying (36).

(b) Consider the error constraint $\|E\| \leq 0.5$.

A similar procedure starts with $t = 0$. Then $y = 1$ and

$$E = 0.5 + 0.25z^{-1}$$

falls within the prescribed bounds and the optimal controller for the unconstrained problem

$$R = \frac{4}{z^{-1} - 2}$$

is optimal in the present sense, too.

(c) Discuss the solutions minimizing $\langle \bar{E}E \rangle$ for the control times $l = 2, 3, \dots; l \geq k_{\min}^0 = 2$. We have $\partial a_0^- = 0, \partial q^- = 1$, and hence $m = l - 2$. Further $\partial b^- = 1$. Therefore, $l = 2$ implies $m < \partial b^-$ and calls for taking $t = 0$, i.e.

$$R = \frac{4}{z^{-1} - 2}, \quad E = 0.5 + 0.5z^{-1}, \quad k_{\min} = 2 \leq l, \quad \langle \bar{E}E \rangle = \frac{1}{2}.$$

Further, $l = 3$ implies $m = \partial b^- + 0$, i.e. $n = 0$ and $t = \tau_0$. Computing

$$\begin{aligned} V &= \frac{1}{4}z + \frac{1}{2} + \frac{1}{4}z^{-1}, \\ \bar{b}^- V b^- &= \frac{1}{64}z + \frac{1}{32} + \frac{1}{64}z^{-1}, \\ \bar{b}^- V j^0 &= \frac{1}{16}z^2 + \frac{1}{8}z + \frac{1}{16}, \end{aligned}$$

equation (8) becomes

$$\frac{1}{32}\tau_0 = \frac{1}{16},$$

i.e. $\tau_0 = 2$. Therefore

$$\begin{aligned} R &= \frac{6 - 2z^1}{(z^{-1} - 2)(1 - 0.5z^{-1})}, \quad E = 0.5 + 0.25z^{-1} - 0.25z^{-2}, \\ k_{\min} &= 3 \leq l, \quad \langle \bar{E}E \rangle = \frac{3}{8}. \end{aligned}$$

Further, $l = 4$ implies $n = 1$ and hence $t = \tau_0 + \tau_1 z^{-1}$, where

$$\begin{bmatrix} \frac{1}{32} & \frac{1}{64} \\ \frac{1}{64} & \frac{1}{32} \end{bmatrix} \begin{bmatrix} \tau_0 \\ \tau_1 \end{bmatrix} = \begin{bmatrix} \frac{1}{16} \\ 0 \end{bmatrix},$$

that is, $\tau_0 = \frac{8}{3}, \tau_1 = -\frac{4}{3}$. It follows that

$$\begin{aligned} (37) \quad R &= \frac{20 - 8z^{-1}}{(z^{-1} - 2)(3 - 2z^{-1} + z^{-2})}, \\ E &= \frac{1}{2} + \frac{1}{6}z^{-1} - \frac{1}{6}z^{-2} + \frac{1}{6}z^{-3}, \quad k_{\min} = 4 \leq l, \quad \langle \bar{E}E \rangle = \frac{1}{3}. \end{aligned}$$

Further, $l \geq 5$ implies $n = l - 3$ and hence $t = \tau_0 + \tau_1 z^{-1} + \dots + \tau_n z^{-n}$, where

$$\begin{bmatrix} \frac{1}{32} & \frac{1}{64} & 0 & \dots & 0 \\ \frac{1}{64} & \frac{1}{32} & 0 & \dots & 0 \\ 0 & 0 & \frac{1}{32} & \dots & 0 \\ \dots & \dots & \dots & \dots & \dots \\ 0 & 0 & 0 & \dots & \frac{1}{32} \end{bmatrix} \begin{bmatrix} \tau_0 \\ \tau_1 \\ \vdots \\ \tau_n \end{bmatrix} = \begin{bmatrix} \frac{1}{16} \\ 0 \\ \vdots \\ 0 \end{bmatrix},$$

that is,

$$\tau_0 = \frac{3}{8}, \quad \tau_1 = -\frac{3}{8}, \quad \tau_2 = \tau_3 = \dots = \tau_n = 0.$$

Thus the optimal controller for any $l \geq 5$ is given by (37) and $k_{\min} = 4 \leq l$. It follows that there is no sense in allowing a control time $l > 4$ because the quadratic norm cannot be less than that for $l = 4$.

Theorem 8. *Problem (32) has a solution if and only if*

- sub (a) $p \mid a$ and the Diophantine equation (25) has a solution x_u, y_u such that $\partial y_u = \min$ subject to $\|a_0 q^- x_u\| \leq \gamma$;
- sub (b) $p \mid a$ and the Diophantine equation (25) has a solution x_e, y_e such that $\partial y_e = \min$ subject to $\|a_0^- q^- y_e\| \leq \gamma$;
- sub (c) $p \mid a$.

The optimal controller is given as a minimal realization of

sub (a)

$$R = \frac{a_0^+ x_u}{y_u}$$

and it is not unique, in general;

sub (b)

$$R = \frac{a_0^+ x_e}{y_e}$$

and it is not unique, in general;

sub (c)

$$R = \frac{a_0^+ x_m}{y_m}$$

and it is unique. Here x_m, y_m is the solution of equation (25) that satisfy $\partial y_m \leq m = l - 1 - \partial a_0^- - \partial q^-$ and $\langle \bar{y}_m V y_m \rangle = \min$, where $V = q^- a_0^- a_0^- q^-$.

Proof. Following the proof of Theorem 4 we conclude that we have to take

$$R = \frac{a_0^+ x}{y}, \quad U = a_0 q^- x, \quad E = a_0^- q^- y,$$

where x, y is a solution of equation (25), in order to make the error vanish in a finite time and thereafter by application of a finite control sequence and have the closed-loop system stable.

Now constraint (a) necessitates a solution x_u, y_u satisfying $\partial y_u = \min$ subject to $\|U\| \leq \gamma$, constraint (b) necessitates a solution x_e, y_e such that $\partial y_e = \min$ subject to $\|E\| \leq \gamma$, while constraint (c) necessitates the solution x_m, y_m such that $1 + \partial a_0^- q^- y_m \leq 1 + \partial a_0^- + \partial q^- + m = l$ and $\langle \bar{y}_m, V y_m \rangle = \min$, where $V = \bar{q}^- a_0^- a_0^- q^-$. It follows that $w = b$ in (8) and $u = a_0^- q^-$.

The existence of the above solutions has been discussed in the Preliminaries. \square

Example 12. Consider the system to be controlled which is a minimal realization of (33) and solve problem (32) for the reference sequence (34).

Equation (25) becomes

$$0.25z^{-1}(z^{-1} - 2)x + (1 - z^{-1})y = 1$$

and its general solution is

$$\begin{aligned} x &= -4 + (1 - z^{-1})t, \\ y &= 1 - z^{-1} - 0.25z^{-1}(z^{-1} - 2)t \end{aligned}$$

for arbitrary $t \in \mathbf{R}[z^{-1}]$. Then

$$R = \frac{x}{y}, \quad U = 0.5(1 + z^{-1})x, \quad E = 0.5(1 + z^{-1})y$$

and the solution $x^0 = -4, y^0 = 1 - z^{-1}$ gives the optimal controller for the associated unconstrained control problem (13).

(a) Consider the control constraint $\|U\| \leq 1$.

Applying the procedure, we first set $t = 0$. Then $x = -4$ and

$$U = -2 - 2z^{-1}$$

does not satisfy the above constraint.

Taking $t = \tau_0$, we get $x = (\tau_0 - 4) - \tau_0 z^{-1}$ and

$$U = -\frac{4 - \tau_0}{2} - 2z^{-1} - \frac{\tau_0}{2}z^{-2}$$

does not evidently satisfy the constraint, either.

Taking further $t = \tau_0 + \tau_1 z^{-1}$, we obtain

$$x = (\tau_0 - 4) + (\tau_1 - \tau_0)z^{-1} - \tau_1 z^{-2}$$

and

$$U = -\frac{4 - \tau_0}{2} - \frac{4 - \tau_1}{2}z^{-1} - \frac{\tau_0}{2}z^{-2} - \frac{\tau_1}{2}z^{-3}.$$

348 The inequalities

$$\begin{aligned} -2 &\leq -4 + \tau_0 \leq 2, \\ -2 &\leq -4 + \tau_1 \leq 2, \\ -2 &\leq -\tau_0 \leq 2, \\ -2 &\leq -\tau_1 \leq 2 \end{aligned}$$

have the unique solution $\tau_0 = \tau_1 = 2$. Therefore, the optimal controller is a minimal realization of

$$R = \frac{-2 - 2z^{-1}}{1 + 0.5z^{-2} - 0.5z^{-3}}$$

and

$$\begin{aligned} U &= -1 - z^{-1} - z^{-2} - z^{-3}, \\ E &= 0.5 + 0.5z^{-1} + 0.25z^{-2} - 0.25z^{-3}, \quad k_{\min} = 4. \end{aligned}$$

(b) Consider the error constraint $\|E\| \leq 0.4$.

We can write

$$E = 0.5 - 0.5z^{-2} + \frac{1}{8}(2z^{-1} + z^{-2} - z^{-3})t$$

and it is seen $\|E\| \geq 0.5$ regardless of t . Hence our problem has no solution.

(c) Find the smallest integer l such that $\langle \bar{E}E \rangle \leq 0.4$. This problem may be motivated by the desire to bound the error indirectly if it cannot be bounded directly.

Since $k_{\min}^0 = 3$, the lowest possible l is three. We have $\partial a_0^- = 0$, $\partial q^- = 1$ and hence $m = l - 2$. Since $\partial b = 2$, we have to take $l = 0$ to obtain $l = 3$. The resulting error

$$E = 0.5 - 0.5z^{-2}$$

gives us $\langle \bar{E}E \rangle = \frac{1}{2} \not\leq 0.4$.

Taking $l = 4$ we obtain $n = 0$, i.e. $t = \tau_0$. Computing

$$\begin{aligned} V &= \frac{1}{4}z + \frac{1}{2} + \frac{1}{4}z^{-1}, \\ \bar{b}Vb &= -\frac{1}{32}z^2 + \frac{1}{64}z + \frac{3}{32} + \frac{1}{64}z^{-1} - \frac{1}{32}z^{-2}, \\ \bar{b}Vy^0 &= \frac{1}{16}z^3 - \frac{1}{16}z^2 - \frac{3}{16}z + \frac{1}{16} + \frac{1}{8}z^{-1}, \end{aligned}$$

equation (8) becomes

$$\frac{3}{32}\tau_0 = \frac{1}{16}$$

and gives $\tau_0 = \frac{2}{3}$. Therefore

$$E = \frac{1}{2} + \frac{1}{6}z^{-1} - \frac{5}{12}z^{-2} - \frac{1}{12}z^{-3}$$

and again $\langle \bar{E}E \rangle = \frac{3}{72} \not\leq 0.4$.

Taking further $l = 5$, we obtain $n = 1$ and $t = \tau_0 + \tau_1 z^{-1}$. Then equations (8) read

$$\begin{bmatrix} \frac{3}{32} & \frac{1}{64} \\ \frac{1}{64} & \frac{3}{32} \end{bmatrix} \begin{bmatrix} \tau_0 \\ \tau_1 \end{bmatrix} = \begin{bmatrix} \frac{1}{16} \\ \frac{1}{8} \end{bmatrix}$$

and we get $\tau_0 = \frac{1}{3} \frac{6}{5}$, $\tau_1 = \frac{4}{3} \frac{4}{5}$. This yields the error

$$E = \frac{1}{2} + \frac{4}{35}z^{-1} - \frac{9}{70}z^{-2} + \frac{1}{10}z^{-3} - \frac{11}{70}z^{-4}$$

and $\langle \bar{E}E \rangle = \frac{27}{245} \approx 0.4$.

Hence we have to take $l = 5$ and the resulting controller is given as a minimal realization of

$$R = \frac{-124 + 28z^{-1} - 44z^{-2}}{35 - 27z^{-1} + 18z^{-2} - 11z^{-3}}$$

CONCLUSIONS

This paper has presented a novel approach to handling control or error constraints in the minimum time control problems. It is assumed that the system is finite dimensional, linear, constant, discrete and having single input and single output. The last assumption is not essential, however; the multivariable case will be discussed in a future paper.

The presented method is very simple and transparent. We display all possible control or error sequences as solutions of a linear Diophantine equation in polynomials and choose the proper solution according to the constraint required. This amounts to solving first the associated unconstrained control problem and then solving a system of simultaneous linear equations or inequalities.

(Received October 24, 1973.)

REFERENCES

- [1] R. E. Kalman, P. L. Falb, M. A. Arbib: Topics in Mathematical System Theory. McGraw-Hill, New York 1969.
- [2] V. Kučera: Algebraic theory of discrete optimal control for single-variable systems I, Preliminaries. *Kybernetika* 9 (1973), 2, 94–107.
- [3] V. Kučera: Algebraic theory of discrete optimal control for single-variable systems II, Open-loop control. *Kybernetika* 9 (1973), 3, 206–221.
- [4] V. Kučera: Algebraic theory of discrete optimal control for single-variable systems III, Closed-loop control. *Kybernetika* 9 (1973), 4, 291–312.
- [5] V. Kučera: Closed-loop stability of discrete linear single-variable systems. *Kybernetika* 10 (1974), 2, 162–187.
- [6] V. Strejc a kol.: Syntéza regulačních obvodů s číslicovým počítačem. NČSAV, Praha 1965.

Ing. Vladimír Kučera, C.Sc.: Ústav teorie informace a automatizace ČSAV (Institute of Information Theory and Automation — Czechoslovak Academy of Sciences), Pod vodárenskou věží 4, 180 76 Praha 8, Czechoslovakia.